

ODL - Mechanical Exchange Box

ODL with CL



Description

This unit is a combination of a key exchange unit and an electrical isolator, for panel or surface mounting. It incorporates one or more rotary switches and any combination of trapped or freed keys. Switches can be either knob (ODS) or lock (ODL) operated and a variety of switch conditions and key sequences are possible. The units are available in single and double row versions (specials are available upon request).

Application

As part of an interlock system, switch control units offer other advantages of key exchange and electrical control within a single unit. Key or knob operated units, ensure power has been isolated before the release of secondary keys.

Construction

Lock mechanism - Brass, with nickel-chrome finish to lock casing and fitted with hinged dustcover. Mounting Plate - Mild Steel with polyester/epoxy finish. Configuration - Number of secondary locks 1 to 17, arranged in one or two rows. Horizontal or vertical mounting. Switches - 16-23A up to 660V AC or 250V DC. Contacts - 4NO or 2NO , 2NC (Other specifications on request).

Back of Board (BOB)

This unit can be fixed behind the machine control panel.

Front of Board (FOB)

This unit is housed in a metal enclosure and is designed to be fixed in front of the machine control panel.

A waterproof (FOB) is available as a special.

Service and Inspection

Regular weekly inspection of the following is necessary to ensure trouble-free, lasting operation:

- 1 Correct switching function
- 2 Secure mounting of components
- 3 Debris and wear
- 4 Loose cable terminals.

If lubrication/cleaning is required for **CL**, **CLS**, **ML** and **MLS** lock portions, use WD40. **Do Not Use Dry Lubricant.**

The frequency of lubrication/ cleaning will depend on the environment. Lubricate/clean at least once a week when used in the concrete industry.

IMPORTANT

This product is designed for use according to the installation and operating instructions enclosed. It must be installed by competent and qualified personnel who have read and understood the whole of this document prior to commencing installation. Any modification to or deviation from these instructions invalidates all warranties. **Fortress Interlocks Ltd.** accepts no liability whatsoever for any situation arising from misuse or mis-application of this product.

This product is not to be used as a Mains Isolator or Emergency Stop. The unit is a component to be added to a permanent electrical installation meeting the requirements of the applicable IEC/EN standards.

The voltages used on the ODL/ODS terminals must all be of the same type i.e. ALL Hazardous Live or ALL Machine Extra Low Voltage.

IF YOU HAVE ANY QUESTIONS OR QUERIES OF ANY NATURE WHATSOEVER PLEASE CONTACT THE SUPPLIER WHO WILL BE PLEASED TO ADVISE AND ASSIST.

Tools and Fixings Required

Back of Board

M6 Tap or Dia. 6.5 Drill
3.5mm Flat Blade Electrical Screwdriver
4 x M6 Screws
4 x M6 Nuts
4 x M6 Washers

Front of Board

M4 Tap or Dia. 4.5 Drill
3.5mm Flat Blade Electrical Screwdriver
4 x M4 Screws
4 x M4 Nuts
4 x M4 Washers

Mounting

Mount this unit well away from sources of vibration or use anti-vibration mountings in order to avoid the effects of vibration shock and bump.

Back of Board (BOB)

Mount the unit only in its correctly assembled condition to flat metal plate of minimum thickness 3.0mm. The plate must be bonded to earth potential. A sound earth connection must be made to the front plate of the product. A shakeproof washer may be required on at least one fixing, to ensure Earth continuity.

- 1 Locate the unit so that all the locks are within easy reach.
- 2 Machine the panel as shown in figure 3.
- 3 Mount the unit to the panel using the 4 M6 screws, nuts and washers, as applicable.
- 4 All fixing screws must be permanently prevented from removal, either by vibration or by personnel using standard tools.

Front of Board (FOB)

Mount the unit only in its correctly assembled condition to flat metal plate of minimum thickness 3.0mm.

- 1 Locate the unit so that all the locks are within easy reach.
- 2 Mount the unit to the panel using the 4 M4 screws, nuts and washers, as applicable. The fixing holes are accessible with the lid removed.
- 3 All fixing screws must be permanently prevented from removal,

Double Row Units

Please contact **Fortress** for dimensional drawings.

Electrical Connection

Check that the unit to be installed is of the same electrical type and voltage rating as the machine control circuits. Note that all units are designed to operate at +/-10% of the nominal supply voltage. The use of an incorrect voltage can seriously damage the unit.

The electrical system must incorporate fuse protection for all circuits, using a Quick-Acting (F) fuse (maximum rating 3A, 250v to IEC 127). Make the electrical connections referring to figures 4 and 5.

Please refer to figure 5 for the Terminal Numbers for the Key Operated Rotary Switch. The earth wire used to bond the unit to Earth potential must be multi-stranded Yellow and Green PVC sheathed and approved to BS 6231 with conductor cross-sectional area of 2.5mm². The Earth lead must be fitted such that it will be the last to be broken if the wiring loom is pulled from the product. When all wiring is complete, conduct a Protective Earth Test to BS 60204, clause 20 to all accessible metal parts. Test the unit for correct operation:-

Installation Instruction

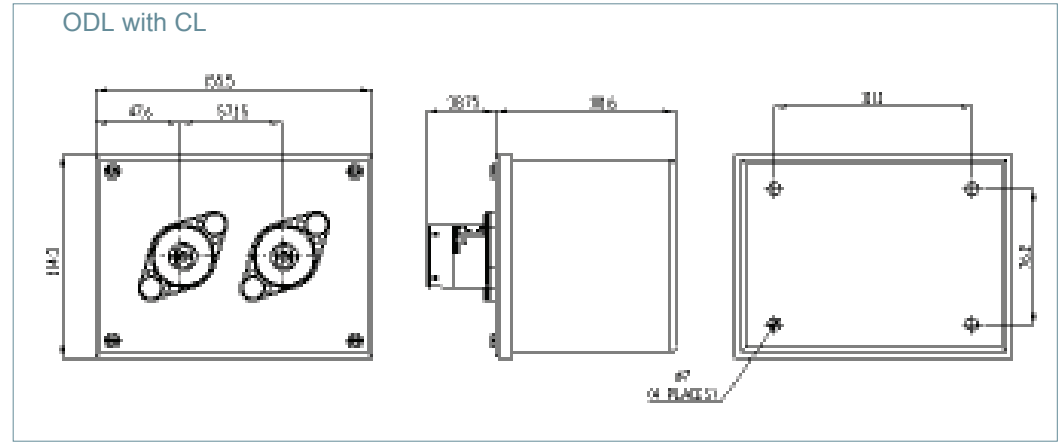

Functionality

KeyGard ODL

In the key exchange condition, secondary keys are normally held captive in the unit and can only be released on insertion and entrapment of the control key(s), which also operates the switch. Alternatively, where all of the keys are normally held captive, the control lock must be released first, operating the switch, before the secondary keys can be freed.

KeyGard ODS

Secondary keys are trapped within the unit when the switch is in the ON position. The switch must be turned to the OFF position, (or state of contact changed), before any of the keys can be removed. Once any of the secondary keys have been removed, the switch cannot be operated and power restored.

Commissioning

Mechanical Function Test

- 1 Isolate electrical supplies.
- 2 Insert all the keys.
- 3 Check that all the keys are trapped in position.
- 4 Check that all the switches are in the states shown in the wiring diagrams - see figure 5.
- 5 Insert all keys.
- 6 Check that the circuits are correct to figure 5.
- 7 Remove the control key (ODL) or operate the switch knob (ODS).
- 8 Check that the rotary switch changes state.

Double Row Units

Please contact **Fortress** for dimensional drawings.

Rotary Switch Wiring Details (With Control Key Removed / Knob Off)

6A/16A 4 N/O	6A/16A 2 N/O 2 N/C	6A/16A 3 N/O 3 N/C
1 — 2	1 — 2	1 — 2
3 — 4	3 — 4	5 — 6
5 — 6	5 — 6	9 — 10
7 — 8	7 — 8	3 — 4
		7 — 8
		11 — 12

Liability coverage is voided under the following conditions:

- 1 If these instructions are not followed
- 2 Non-compliance with safety regulations.
- 3 Installation and electrical connection not performed by authorised personnel.
- 4 Non-implementation of functional checks.

Environmental Specification

Environment Type	Indoor
Max. Altitude	2000m
Ambient Temperature	-5°C to +40°C
Maximum Relative Humidity	80%@<=31°C 50%@40°C
Transient Overvoltages Installation	Uimp 2500V
Pollution Degree(IEC 664)	2
Maximum Relative Humidity	-5°C to +40°C 80%@<=31°C 50%@40°C
Transient Overvoltages Installation	Uimp 2500V
Pollution Degree	(IEC 664)