

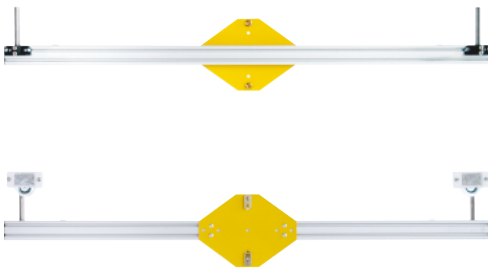

MMS-P



Muting Mounting System

The MMS Muting-Mounting-System enables in combination with light grids with integrated Muting (Areal-M, COMPACTplus) or ROBUST with MCB and Mounting columns UDC/DC to realize complete Muting-Applications in a easy and convenient manner.

Advantages

- Mounting system for Muting-Applications
- Slim, attractively designed profile
- Flexible mounting plate for attaching the MMS to the column
- Mounting of Muting-Sensors to MMS with 12 mm-V2A-round rods
- Adjustment of sensors horizontal and vertical in a big range
- MMS-P-1000-P includes reflectors and mounting devices
- For the direct assembly of Leuze sensors of the series 46

Areas of Application

Mounting of muting sensors and -reflectors to freestanding mounting columns UDC/DC.

Dimensional Drawings

MMS-A-1000-P

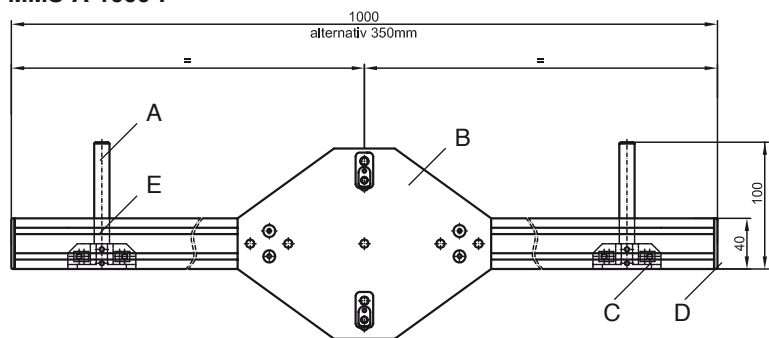

A = V2A-round rod 12x100 mm
 B = Mounting plate
 C = Alu profile

D = Cap
 E = Mounting device UMS 1.03

MMS-P-1000-P

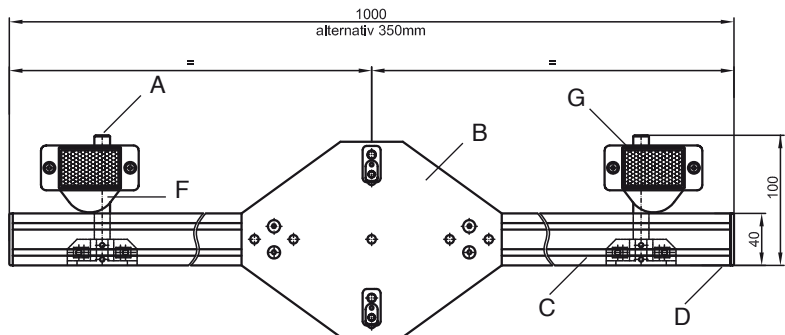

A = V2A-round rod 12x100 mm
 B = Mounting plate
 C = Alu profile
 D = Cap

E = Mounting device UMS 1.03
 F = Mounting device BT 46.1
 G = Reflector TK 30x50

Order Details

Type	Order No.
MMS-A-1000-P active part - length 1000 mm	548800
MMS-P-1000-P passive part - length 1000 mm	548801
MMS-A-350 active part - length 350 mm	548804
MMS-P-350 passive part - length 350 mm	548803

Other lengths on request. Sliding locks and screws included.



Leuze lumiflex GmbH + Co. KG

Liebigstraße 4
 D-82256 Fürstenfeldbruck, Germany
 Tel. +49 - (0) 81 41-5350-0
 Fax +49- (0) 8141-53 50-190
 e-mail: lumiflex@leuze.de
 www.leuze.de