

UM60-300...1050

Deflecting Mirrors for Safety light curtains



The Deflecting Mirrors with narrow mirror carrier are used for the beam deflection of light curtains in order to achieve multi- sided safeguarding of danger zones. Sliding blocks and mounting brackets (accessories) allow a easy and precise alignment.

Advantages

- continuous mirror surface for beam deflection of light curtains
- sturdy aluminium profile
- narrow and flat construction
- Mounting brackets allow mounting and alignment in the preference angles 0, 45, 90° as well as swivel-mounted.

Areas of Application

Multi sided safeguarding of danger zones in combination with safety light curtains of the ECO, COMPACT or COMPACT *plus* series.

UM60-300...1050
Dimensional Drawings

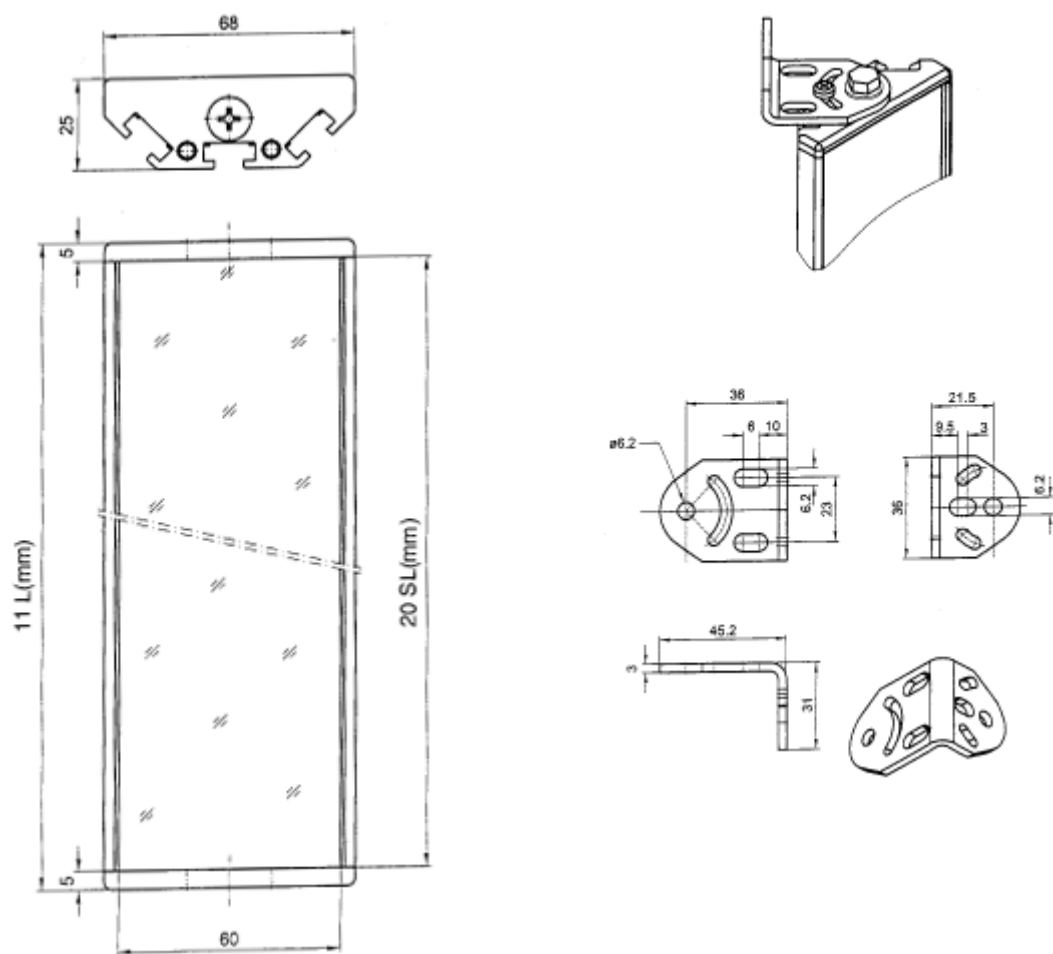

Dimensional table:

Type	Continuous mirror length [mm]	Mirror carrier [mm]
UM60-300	360	370
UM60-450	510	520
UM60-600	660	670
UM60-750	810	820
UM60-900	960	970
UM60-1050	1110	1120

UM60-300...1050

Technical Data

Mirrors	Continuous mirror surface
Housing	Aluminium profile housing
Surface	Powder varnished, yellow (RAL 1021)
Range	Reduction per deflection of about 10%