

Protective Door Bolts BL and BS

Accessories for Safety Interlocking Devices



BL and BS Safety Door Bolts for Safety Interlocking Devices S10 and L50.

The Series BL and BS safety door bolts with integrated telescope actuators serve as a prefabricated mounting support and eliminate the need for the user to undertake mechanical adaptive measures. At the same time, the safety door bolts act as an end stop and protect the interlocking devices from sustaining damage.

Advantages

- Allows quick and proper mounting of safety interlocking devices
- Simple mounting on aluminum profiles, square pipes and machine cover panels
- Universally suitable for right-stopped or left-stopped safety doors
- Mechanical end stop function protects the interlocking devices
- Prevents the machinery from starting up inadvertently due to accidental closing
- Suitable for safety interlocking devices Series S10 and L50

Protective Door Bolts BL and BS

Dimensional Drawings

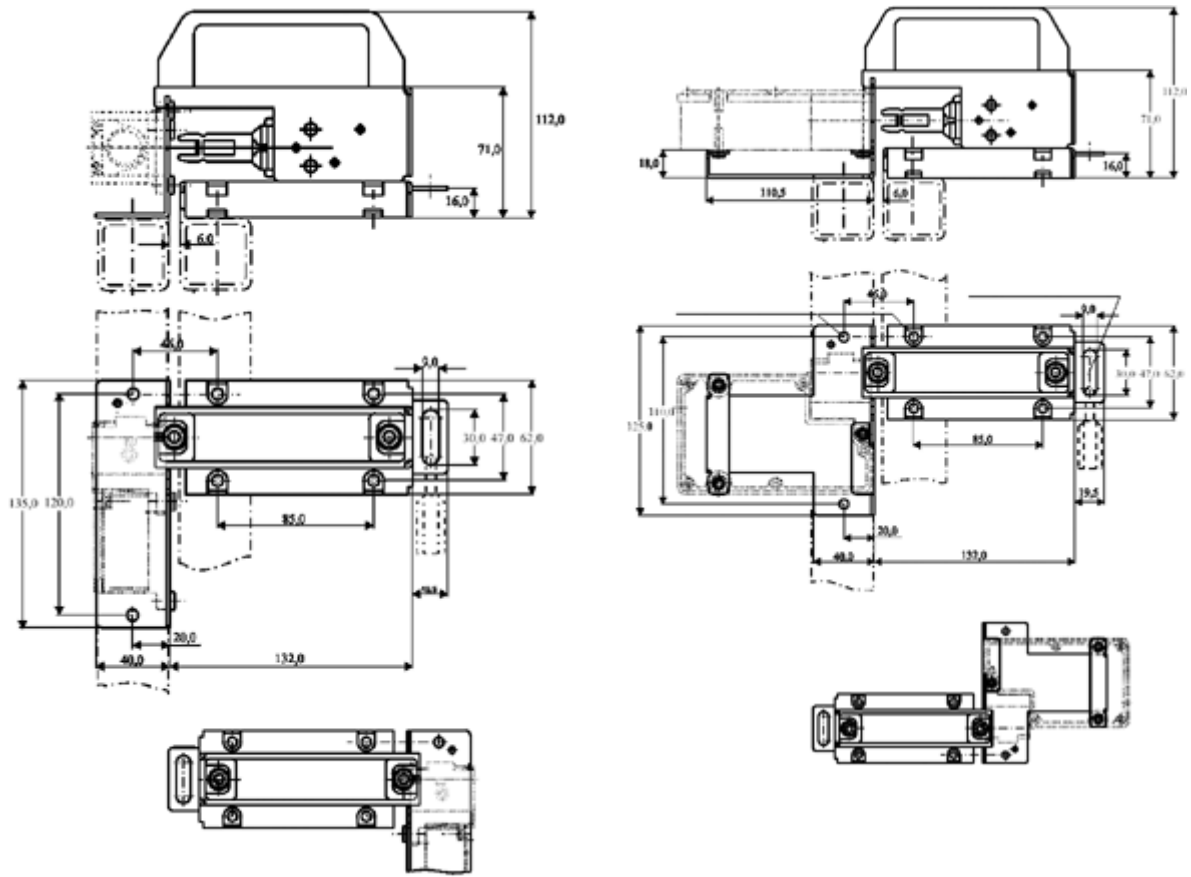

Protective Door Bolts BL and BS

Technical Data

Technical Data	series		
	BL-L50	BS-L50	BL-S10
Design	Bent-plate part	Flat-bar steel 8 mm with plastic-guiding	Flat-bar steel 8 mm with plastic-guiding
Installed actuator	Telescop actuator	Standard actuator	Standard actuator
Delivery includes	Door bolt incl. actuator and mounting angle bracket	Door bolt incl. actuator and mounting angle bracket	Door bolt incl. actuator and mounting angle bracket