



SLS 96

Protective throughbeam photoelectric sensors



65 m
39 m



- Protective throughbeam photoelectric sensor cat. 2 (testing) with high performance reserve in visible red light or infrared light
- Robust metal housing with glass cover or plastic housing, protection class IP 67 for industrial application
- 2 indicators each at the transmitter and receiver for displaying their status when commissioning and in operation
- Optics heating for use with low temperatures
- Connection via M12 connector or terminal compartment



We reserve the right to make changes • 96_a07e.fm

Accessories:

(available separately)

- Mounting systems (BT 96, BT 96.1, UMS 96, BT 450.1-96)
- M12 connectors (KD ...)
- Alignment aid ARH 96
- Test-monitoring units:
 - TNT 32 (Part No. 500 20476)
 - TNT 33 (Part No. 500 28158)
 - TNT 34 (Part No. 500 81023)
 - TNT 35 (Part No. 500 33058)
 - TMC 66 (Part No. 500 82121)

Dimensioned drawing

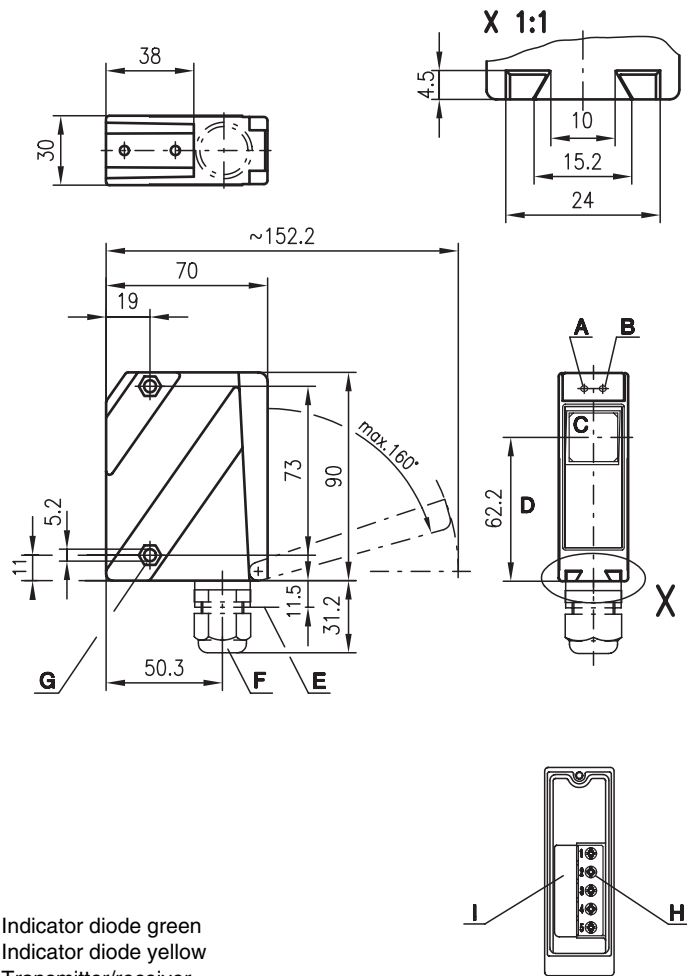

- A Indicator diode green
- B Indicator diode yellow
- C Transmitter/receiver
- D Optical axis
- E Device plug M12x1
- F Screwed cable gland M16x1.5 for Ø 5 ... 10mm
- G Countersinking for SK nut M5, 4.2mm deep
- H Connection terminals
- I Cable entry

Electrical connection

Transmitter

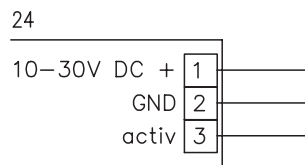

Receiver

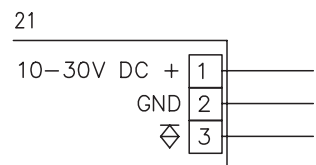

45

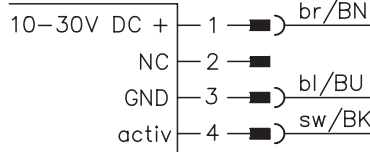

41

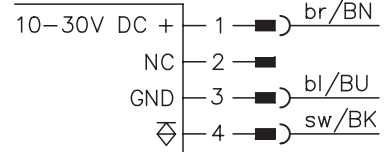



Specifications

Optical data	Infrared light	Red light
Typ. operating range limit ¹⁾	0 ... 65m	0 ... 39m
Operating range ²⁾	0 ... 50m	0 ... 30m
Light source	LED (modulated light)	LED (modulated light)
Wavelength	880nm	660nm
Timing		
Sensor switching frequency	500Hz	
Sensor response time	1 ms	
Delay before start-up	≤ 200ms	
Electrical data		
Operating voltage U _B	10 ... 30VDC (incl. residual ripple)	
Residual ripple	≤ 15% of U _B	
Bias current	≤ 50mA	
Switching output	PNP transistor	
Function characteristics	light switching	
Signal voltage high/low	≥ (U _B -2V)/≤ 2V	
Output current	max. 100mA	
Indicators		
LED green	ready	
Receiver		
LED yellow	light path free	
LED yellow flashing	light path free, no performance reserve	
Transmitter		
LED yellow	transmitter active	
Mechanical data	Metal housing	
Housing	diecast zinc	
Optics cover	glass	
Weight	380g	
Connection type	terminals or M12 connector	
Environmental data		
Ambient temp. (operation/storage)	-20°C ... +60°C/-40°C ... +70°C	
Protective circuit ³⁾	1, 2, 3	
VDE safety class ⁴⁾	II, all-insulated	
Protection class	IP 67	
Standards applied	IEC 60947-5-2	
Options		
Optics heating	for temperature changes, prevents fogging	
Low temperature	to -35°C	
Activation input activ		
Transmitter active/not active	≥ 8V/≤ 2V	
Activation/disable delay	≤ 1 ms	
Input resistance	10KΩ ± 10%	

- 1) Typ. operating range limit: max. attainable range without performance reserve
- 2) Operating range: recommended range with performance reserve
- 3) 1=transient protection, 2=polarity reversal protection, 3=short-circuit protection for all outputs
- 4) Rating voltage 250VAC

Tables

Remarks

- The protective through-beam photoelectric sensor is a contactless active protective device only in connection with a safety-relevant control system, in which the cyclical testing of transmitter and receiver is carried out according to EN 61496-1, category 2 (testing).
- The power supply unit used to operate the photoelectric sensor has to be able to compensate for changes and interruptions of the supply voltage acc. to EN 61496-1. Minimum blackening object: Ø 28mm.

SLS = Pair consisting of
 SLSS = Transmitter
 SLSE = Receiver

Order guide

Selection table		Order code →						
Equipment ↓		SLS 96M/P-1070-T2-2 Part No. 500 25213 (Tr) Part No. 500 25192 (Re)	SLS 96M/P-1070-T2-4 Part No. 500 25215 (Tr) Part No. 500 25193 (Re)	SLS 96M/P-1071-T2-2 Part No. 500 29454 (Tr) Part No. 500 29455 (Re)	SLS 96M/P-1071-T2-4 Part No. 500 80478 (Tr) Part No. 500 80479 (Re)	SLS 96M/P-1200-T2-2 Part No. 500 25209 (Tr) Part No. 500 31562 (Re)	SLS 96M/P-1200-T2-4 Part No. 500 31249 (Tr) Part No. 500 31250 (Re)	
Housing	metal	●	●	●	●	●	●	
	plastic							
Light source	red light (30m)					●	●	
	infrared light (50m)	●	●	●	●			
Connection	terminals	●		●		●		
	M12 connector		●		●		●	
Features	optics heating/low temp.			●	●			
	activation input	●	●	●	●	●	●	
	filter for multi-axis operation							

- SLS 96M/P-1070-T2-2**
 SLSS 96M-1080-T2-24
 SLSE 96M/P-1070-T2-21
- SLS 96M/P-1070-T2-4**
 SLSS 96M-1080-T2-45
 SLSE 96M/P-1070-T2-41
- SLS 96M/P-1071-T2-2**
 SLSS 96M-1090-T2-24
 SLSE 96M/P-1071-T2-21
- SLS 96M/P-1071-T2-4**
 SLSS 96M-1090-T2-45
 SLSE 96M/P-1071-T2-41
- SLS 96M/P-1200-T2-2**
 SLSS 96M-1210-T2-24
 SLSE 96M/P-1200-T2-21
- SLS 96M/P-1200-T2-4**
 SLSS 96M-1210-T2-45
 SLSE 96M/P-1200-T2-41