



ODSL 8

Optical laser distance sensors



Dimensioned drawing

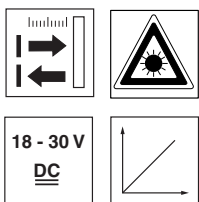

20 ... 400 mm

- Reflection-independent distance information
- Highly insensitive to extraneous light
- Analogue current and voltage output
- Measurement range and mode adjustable
- Teachable switching output
- M12 turning connector

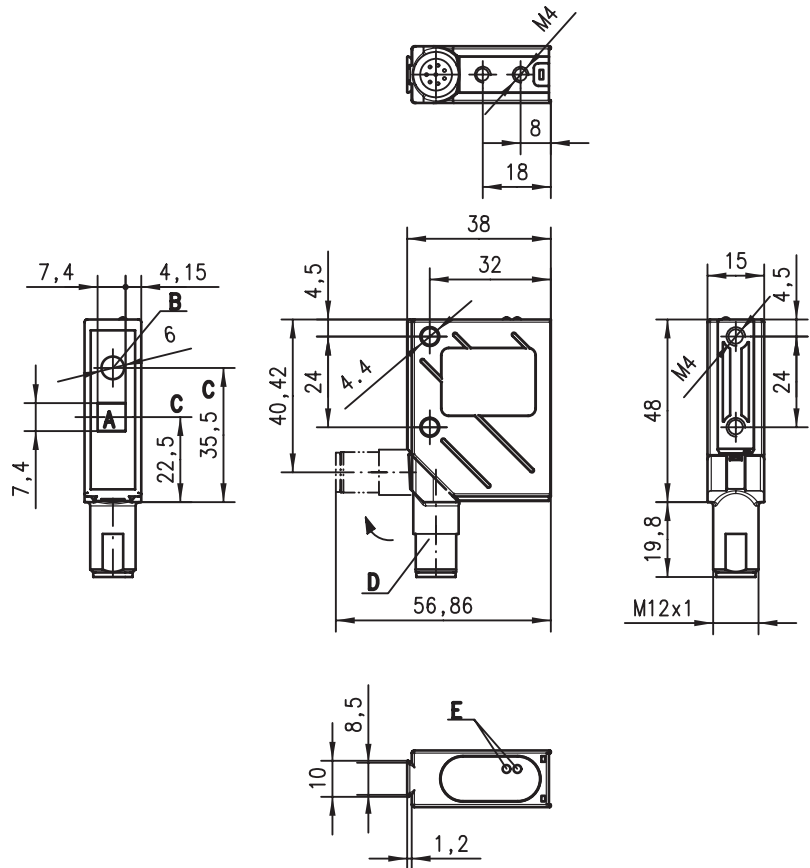

- A Transmitter
- B Receiver
- C Optical axis
- D 90° turning connector
- E LED yellow, green

Electrical connection

18-30V DC +	1	ws/WH
	2	br/BN
GND	3	gn/GN
1. ⚡	4	ge/YE
teach in	5	gr/GR
4-20mA	6	rs/PK
1-10V	7	bl/BU
Analog GND	8	rt/RD

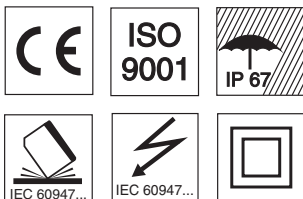

Accessories:

(available separately • see page 72)

- Mounting systems
- Programming software
- Ready-made cable KB 448-2000-8A
- Control guard

We reserve the right to make changes • ods_12e.fm

Specifications

Optical data

Measurement range ¹⁾	20 ... 400mm
Resolution	0.1 mm
Light source	laser (modulated light)
Wavelength	650 nm (visible red light)
Light spot diameter	divergent, 1x6mm at 400m
Laser class	2 acc. to EN 60825-1 (2003/10)
Laser warning notice	see remarks

Error limits

Absolute measurement accuracy ¹⁾	± 1% up to 200mm / ± 2% 200 ... 400mm (6 ... 90% diffuse reflection)
Repeatability ²⁾	± 0.25% up to 200mm / ± 1% 200 ... 400mm (6 ... 90% diffuse reflection)
Linearity	0.5% at 90% (white)

Timing

Measurement frequency	200Hz / 5ms measurement time
Response time	≤ 20 ms
Delay before start-up	≤ 300ms

Electrical data

Operating voltage U_B	18 ... 30VDC (incl. residual ripple)
Residual ripple	≤ 15% of U_B
Bias current	≤ 50mA
Switching output	PNP transistor, high-active
Signal voltage high/low	≥ ($U_B - 2V$) / ≤ 2V
Analogue output	$R_L \geq 2k\Omega$ (voltage) $R_L \leq 500\Omega$ (current)

Indicators

LED green	continuous light	teach-in on GND	teach-in on +U_B
	flashing	ready for operation	
	off	error	teaching procedure
LED yellow	continuous light	no voltage	
	flashing	object inside teach-in measurement distance	teaching procedure
	off	object outside teach-in measurement distance	

Mechanical data

Housing	metal
Optics cover	glass
Weight	70g
Connection type	M12 connector, 8-pin, turning

Environmental data

Ambient temp. (operation/storage)	-20°C ... +50°C / -40°C ... +70°C
Protective circuit ³⁾	2, 3
VDE safety class ⁴⁾	II, all-insulated
Protection class	IP 67
Standards applied	IEC 60947-5-2

- 1) Luminosity coefficient 6% ... 90%, over complete temperature range, measured object ≥ 50x50mm²
 2) Same object, measured object ≥ 50x50mm²
 3) 2=polarity reversal protection, 3=short-circuit protection for all outputs
 4) Rating voltage 250VAC

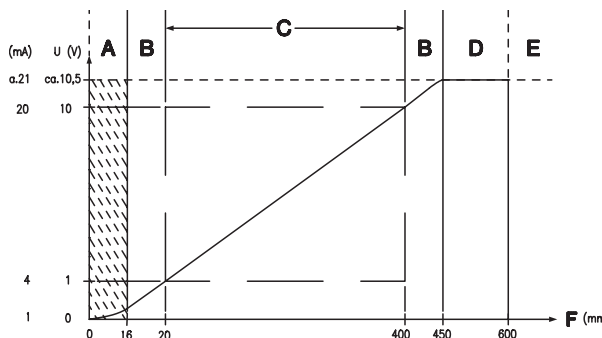

- A** Area not defined
B Linearity not defined
C Measurement range
D Object present
E No object detected
F Measurement distance

Order guide

	Designation	
M 12 connector	ODSL 8/V4-400-S12	500 39614
Programming terminal	UPG 5	500 39627

Tables

Diagrams

Remarks

- Switching frequency depends on the reflectivity of the measured object and on the measurement mode.
- Teaching procedure:** Position measured object at desired measurement distance. Connect teach input to + U_B for ≥ 2s. Reconnect teach input to GND, switching output is programmed.
- In the analogue version, the voltage output is calibrated.

LASER LIGHT DO NOT STARE INTO BEAM	
Maximum Output:	1.2mW
Pulse duration:	4ms
Wavelength:	650nm
CLASS 2 LASER PRODUCT EN60825-1:2003-10	

LASER LIGHT DO NOT STARE INTO BEAM	
Maximum Output:	1.2mW
Pulse duration:	4ms
Wavelength:	650nm
CLASS 2 LASER PRODUCT IEC 60825-1:1993+A2:2001 Complies with 21 CFR 1040.10	