



## ODS 96

## Optical distance sensors



100 ... 600mm



- Reflection-independent distance information
- Highly insensitive to extraneous light
- Analogue current or voltage output
- Measurement range and mode adjustable
- Teachable switching output



### Accessories:

(available separately)

- Mounting systems
- Programming software

### Dimensioned drawing

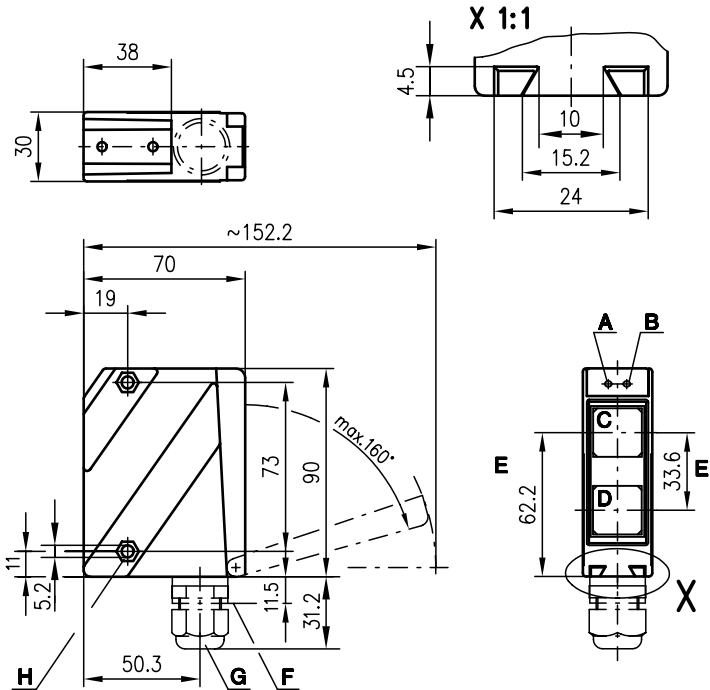

- A Indicator diode green
- B Indicator diode yellow
- C Transmitter
- D Receiver
- E Optical axis
- F Device plug M12x1
- G Screwed cable gland PG 11 for Ø5 ... 10mm
- H Countersinking for SK nut M5, 4.2mm deep
- I Parameter plug
- K Connection terminals
- L Cable entry

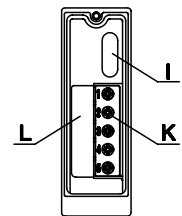

### Electrical connection

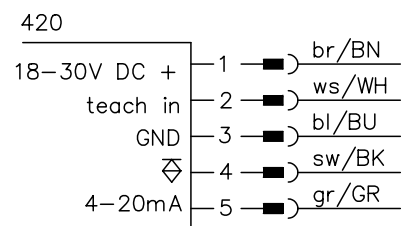
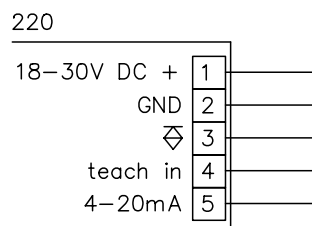
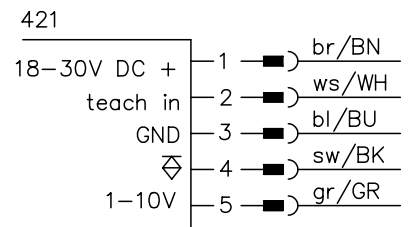
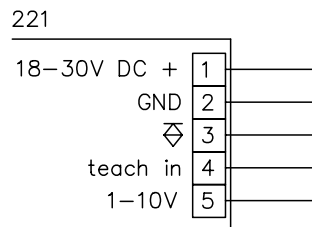

We reserve the right to make changes • ods\_06e.fm

### Specifications

#### Optical data

Measurement range <sup>1)</sup>	100 ... 600mm
Resolution	≤ 0.5mm
Light source	LED (modulated light)
Wavelength	880nm (infrared)
Light spot diameter	approx. 10mm (over entire measurement range)

#### Error limits

Absolute measurement accuracy <sup>1)</sup>	± 2% (relative to the measurement distance)
Repeatability <sup>2)</sup>	± 0.5%
b/w detection thresholds (6%/90%)	< 1%

#### Timing

Switching frequency	20 ... 100Hz
Response time	≤ 100ms
Delay before start-up	≤ 300ms

#### Electrical data

Operating voltage $U_B$	18 ... 30VDC (incl. residual ripple)
Residual ripple	≤ 15% of $U_B$
Bias current	≤ 150mA
Switching output	PNP transistor, high-active
Signal voltage high/low	≥ ( $U_B - 2V$ ) / ≤ 2V
Analogue output	$R_L \geq 2k\Omega$ (voltage) $R_L \leq 500\Omega$ (current)

#### Indicators

LED green	continuous light	<b>teach-in on GND</b>	<b>teach-in on +<math>U_B</math></b>
	flashing	ready	
	off	error	teaching procedure
LED yellow	continuous light	no voltage	
	flashing	object inside teach-in measurement distance	teaching procedure
	off	object outside teach-in measurement distance	

#### Mechanical data

Housing	diecast zinc
Optics cover	glass
Weight	380g
Connection type	terminals or M12 connector

#### Environmental data

Ambient temp. (operation/storage)	-20°C ... +50°C / -30°C ... +70°C
Protective circuit <sup>3)</sup>	1, 2, 3
VDE safety class <sup>4)</sup>	II, all-insulated
Protection class	IP 67
Standards applied	IEC 60947-5-2

- 1) Luminosity coefficient 6% ... 90%, over complete temperature range, measured object ≥ 50x50mm<sup>2</sup>  
 2) Same object, measured object ≥ 50x50mm<sup>2</sup>  
 3) 1=transient protection, 2=polarity reversal protection, 3=short-circuit protection for all outputs  
 4) Rating voltage 250VAC

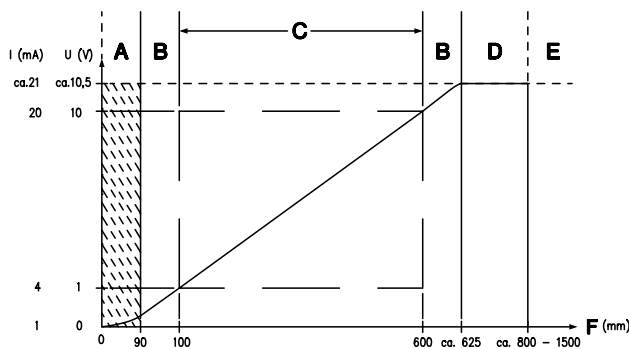

- A** Area not defined  
**B** Linearity not defined  
**C** Measurement range  
**D** Object present  
**E** No object detected  
**F** Measurement distance

### Order guide

	Designation	Part No.
<b>Terminals</b>		
Current output	ODS 96M/V-5000-600-220	500 81127
Voltage output	ODS 96M/V-5010-600-221	500 81128
<b>M12 connector</b>		
Current output	ODS 96M/V-5000-600-420	500 81129
Voltage output	ODS 96M/V-5010-600-421	500 81130

### Tables

### Diagrams

### Remarks

- Switching frequency depends on the reflectivity of the measured object and on the measurement mode.
- **Teaching procedure:** Position measured object at desired measurement distance. Connect teach input to + $U_B$  for ≥ 2s. Reconnect teach input to GND, switching output is programmed.