



PRK 318

Retro-reflective photoelectric sensors with polarisation filter



0.02 ... 6.0m



- Polarised retro-reflective photoelectric sensors with straight optics using visible red light
- Robust cylindrical stainless steel or plastic housing M18x1, protection class IP 67 for industrial application
- Complementary outputs for light/dark switching or as a control function
- Very short construction for application in limited spaces

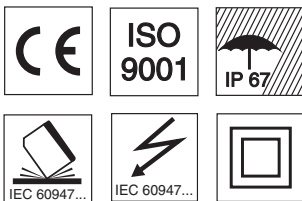

Accessories:

(available separately)

- Mounting systems (BT 318)
- M12 connectors (KD ...)
- Ready-made cables (KB ...)
- Reflectors
- Reflective tape

Dimensioned drawing

... 318M/...

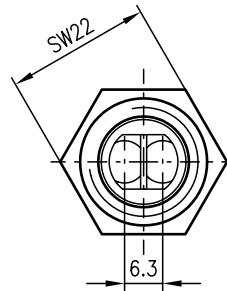
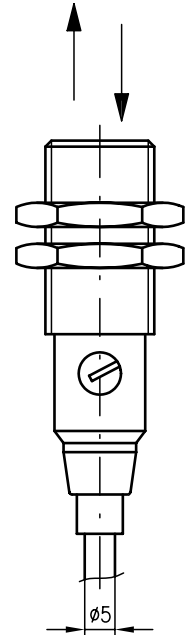
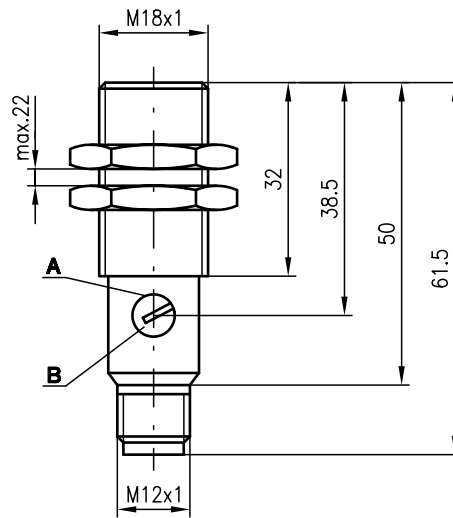

... 318K/...

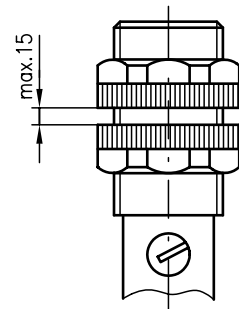

- A** Indicator diode
- B** Sensitivity adjustment

Electrical connection

PRK 318M/P-S12
PRK 318K/P-S12

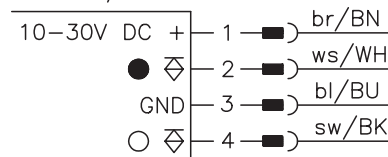

PRK 318M/P
PRK 318K/P

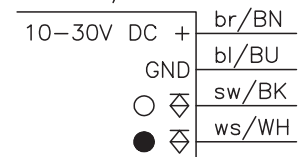

Specifications

Optical data

Typ. operating range limit (TK(S) 100x100) ¹⁾	0.02 ... 6.0m
Operating range ²⁾	see table
Light source	LED (modulated light)
Wavelength	660nm (visible red light, polarised)

Timing

Switching frequency	1000Hz
Response time	0.5ms
Delay before start-up	≤ 30ms

Electrical data

Operating voltage U_B	10 ... 30VDC
Residual ripple	≤ 10% of U_B
Bias current	≤ 15mA
Switching output	2 transistor outputs, complementary
Function characteristics	light/dark switching
Signal voltage high/low	≥ ($U_B - 1.6 V$) ≤ 1.6 V
Output current	max. 100mA
Sensitivity	adjustable

Indicators

LED red	light path free
LED red flashing	light path free, no performance reserve

Mechanical data

Housing	polyamide 12 or stainless steel
Optics cover	acrylic
Weight	90g (cable), 20g (M12)
Connection type	M12 connector, 4-pin cable 2m, 4 x 0.25mm ²

Environmental data

Ambient temp. (operation/storage)	-25°C ... +65°C/-40°C ... +70°C
Protective circuit ³⁾	1, 2, 3, 4
VDE safety class ⁴⁾	II, all-insulated
Protection class	IP 67
Standards applied	IEC 60947-5-2

- 1) Typ. operating range limit: max. attainable range without performance reserve
- 2) Operating range: recommended range with performance reserve
- 3) 1=transient protection, 2=polarity reversal protection, 3=short circuit protection for all outputs, 4=interference blanking
- 4) Rating voltage 250VAC

Order guide

Selection table		PRK 318K/P-S12 Part No. 500 81347	PRK 318K/P Part No. 500 81348	PRK 318M/P-S12 Part No. 500 81349	PRK 318M/P Part No. 500 81350				
Order code →									
Equipment ↓									
Housing	plastic	●	●						
	stainless steel			●	●				
Connection	M12 connector	●		●					
	cable		●		●				
Switching output	PNP	●	●	●	●				
	NPN								

Tables

Reflectors	Operating range
1 TK(S) 100x100	0.03 ... 4.6m
2 TK(S) 47x47	0.02 ... 3.2m
3 TK(S) 30x50	0.03 ... 2.2m
4 TK(S) 20x40	0.06 ... 1.9m
5 Tape 2 100x100	0.24 ... 2.0m

1	0.03		4.6	6.0
2	0.02		3.2	4.6
3	0.03	2.2	3.2	
4	0.06	1.9	2.9	
5	0.24	2.0	3.1	

- Operating range [m]
- Typ. operating range limit [m]

- TK ... = adhesive
- TKS ... = screw type
- Tape 2 = adhesive

Diagrams

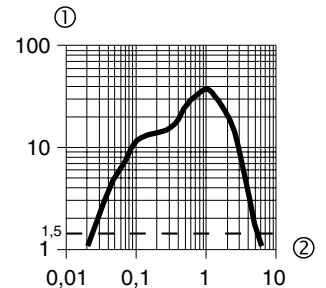
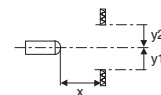
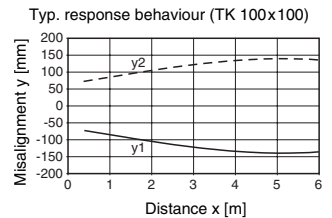

Typical behaviour reflector distance/relative intensity of received light (with reflector TK(S) 100x100)

- ① relative intensity of received light
- ② reflector distance [m]

Remarks

- Models with NPN transistor output on request.