

# Rotary Measuring Technology

## Absolute Multiturn Encoder with optional incremental track

### Multiturn Type 5882 SSI or RS 485, programmable



- Most compact multiturn encoder with hollow shaft on the market
- Only 40.5 mm clearance needed, thus lower profile than incremental encoders.
- Programming parameters include\*: code type, resolution per revolution, total resolution, direction of rotation (cw or ccw), zero point.
- Very easy mounting of the hollow shaft version. The encoder is mounted directly on the drive shaft without coupling.
- Divisions: up to 8192 (13 bits) per revolution

\* with optional programming kit (Ezturn®) see accessories

- 4096 (12 bits) revolutions
- SSI interface, additional interfaces include RS 485 and OEM specific protocols
- Multiturn gear with patented intelligent sensing technology (I-S-T)
- Hollow shaft up to Ø 12 mm
- Housing Ø 58 mm, Protection: IP 65
- Shock resistant up to 250 g
- optional with incremental track 2048 ppr
- available as explosion proof zone 2 and 22

#### Divisions and code types available at short notice:

- 24 Bit Binary / Gray
- 25 Bit Binary / Gray
- Other divisions and code types on request

#### The programmable SSI versions are available in 3 variants:

##### Order code Interface 2:

Version with 4 programmable outputs

##### Order code Interface 4:

Version with incremental outputs A,A,B,B (no programmable outputs)

##### Order code Interface 9:

Version with 2 programmable outputs and 2 sensor outputs for 0 V and +U<sub>B</sub> for controlling the supply voltage on the encoder.

#### Mechanical characteristics:

Speed: <sup>1)</sup>	max. 6 000 min <sup>-1</sup>
Rotor moment of inertia:	appr. 6 x 10 <sup>-6</sup> kgm <sup>2</sup>
Starting torque hollow shaft version:	< 0,05 Nm
Weight:	appr. 0,5 kg
Protection acc. to EN 60 529:	IP 65
Working temperature: <sup>2)</sup>	-20° C ... +70 °C
Operating temperature:	-20° C ... +80 °C
Shaft:	stainless steel
Shock resistance acc. to DIN-IEC 68-2-27	2500 m/s <sup>2</sup> , 6 ms
Vibration resistance acc. to DIN-IEC 68-2-6:	100 m/s <sup>2</sup> , 10 ... 2000 Hz

1) for continuous operation 3000 min<sup>-1</sup>

2) non-condensing

#### Electrical characteristics:

Interface type:	Synchronous-Serial (SSI) with outputs
<b>General information:</b>	
Supply voltage (U <sub>B</sub> ):	5,0 ... 30 V DC <sup>3)</sup>
Current consumption type (no load):	89 mA
max (no load):	138 mA
Short circuit proof outputs: <sup>1)</sup>	yes <sup>2)</sup>
Reverse connection protection at U <sub>B</sub> :	yes
<b>SSI-Interface:</b>	
Output driver:	RS 485
Permissible load/channel:	max. +/- 20 mA
Update rate for position data:	appr. 1600/s
SSI pulse rate min./max./pulse frequency:	100 kHz/500 kHz
Signal level high:	typ. 3,8 V
Signal level low (I <sub>Last</sub> = 20 mA):	typ. 1,3 V
Rise time t <sub>r</sub> (without cable):	max. 100 ns
Fall time t <sub>f</sub> (without cable):	max. 100 ns
<b>Control inputs:</b>	
Voltage:	5 ... 30 V DC = U <sub>B</sub>
(V/R, SET) Response time:	10 ms
Signal level: low	max. 25% U <sub>B</sub>
high	min. 60% U <sub>B</sub> , max. U <sub>B</sub>
Max. current input	≤ 0,5 mA

#### Status outputs:

Output driver:	Push-Pull
max. permissible load:	±9,0 mA
Signal level high:	min. U <sub>B</sub> - 3,0 V
low:	max. 1,5 V
Rise time:	max. 240 µs
Fall time:	max. 300 µs

#### Incremental outputs (A/B):

Output driver:	RS422 compatible
Puls frequency (max.):	200 kHz
Signal level high:	4,5 V
Signal level low (I <sub>Last</sub> = 20 mA):	0,5 V
Rise time (without cable):	max. 200 ns
Fall time (without cable):	max. 200 ns

Conforms to CE requirements acc. to EN 61000-6-1, EN 61000-6-4 and EN 61000-6-3

Performance against magnetic influence acc. to EN61000-4, 5

1) when U<sub>B</sub> supply voltage correctly applied U<sub>B</sub>

2) Only one channel at a time:

When U<sub>B</sub> = 5 V DC, short-circuit to output, 0 V and + U<sub>B</sub> is permitted.  
When U<sub>B</sub> < 5 V DC short-circuit to output and 0 V is permitted.

3) The supply voltage at the encoder input must not be less than 4.75 V (5 V - 5%)

### Multiturn Type 5882 SSI or RS 485, programmable

#### Control inputs:

##### F/R input for change of direction:

The encoder can output increasing code values when the shaft is rotated either clockwise or counter-clockwise (when looking from the shaft side).

There are two methods for selecting the appropriate option:

1. Via a hardware configuration of the F/R input BEFORE powering up the encoder
2. By programming the device using the Kübler "EzTurn" programming tool.

The following table shows the function selection dependent on hardware and software settings:

Hardware configuration of the F/R input:

Hardware configuration of the F/R input	Programmed selection using the EzTurn" programming tool	Function: increasing code value when the shaft is in the following direction:
"low" (0V) on the F/R input (=cw)	cw	cw
"high" (+UB) on the F/R input (= ccw)	cw	ccw
"low" (0V) on the F/R input (=cw)	ccw	ccw
"high" (+UB) on the F/R input (= ccw)	ccw	ccw

#### Notes:

- Any hardware configuration of the F/R input must take place BEFORE powering up the encoder!
- If the F/R input is not configured, then a 0V configuration will apply (default condition)!
- If the direction of rotation is changed due to the F/R configuration, without activating the SET function again, and if the encoder is also then powered up again, a new position value may be outputted, even if the physical shaft position of the encoder has not moved! This is due to internal conversion processes.

The start-up procedure for the encoder should therefore follow this sequence:

1. Determine the count direction of the encoder either via the F/R input or via programming
2. Apply power to the encoder
3. Activate the SET function, if desired (see SET input below)

- If using a cable wire to configure the F/R input, then for EMC reasons the wire should not remain open but should be tied either to 0V or UB!
- The response time of the F/R input with UB = 5 ... 30 V DC power supply is 10 ms.

#### SET input:

This input is used for a one-time alignment (zeroing) of the encoder immediately after installation. A high control pulse (+UB) applied to this input for a minimum of 10 ms will reset the current encoder position to the pre-programmed setpoint value.

The programming of the setpoint can be carried out with Kübler's Ezturn® programming software or can, on request, be done in advance at the factory. The default value is zero. However any value within the encoder's measuring range can be defined.

#### Notes:

- The SET function should only be implemented when the encoder shaft is at rest.
- For the duration of the SET pulse the SSI interface does not function and therefore does not output any valid position values! In order to avoid malfunctions, no SSI clock pulse should occur during the SET pulse.
- If a cable wire is used to configure the SET input, then for EMC reasons the wire should not remain open but should if at all possible be tied to 0 V, provided no SET pulse is triggered!
- The response time of the SET input with +UB = 5 ... 30 V DC power supply is 10 ms.

#### Encoder outputs<sup>1)</sup>

Output	Default-function:
A1:	battery control <sup>2)</sup>
A2:	not activated <sup>2)</sup>
A3:	not activated <sup>2)3)</sup>
A4:	not activated <sup>2)3)</sup>

The outputs are not activated in the factory setting (default). They can be activated and defined with the optional Ezturn® programming software e.g. limit switch, overspeed and temperature control etc.

<sup>1)</sup>not available for versions with incremental track

<sup>2)</sup>programmable with the optional programming software Ezturn®

<sup>3)</sup>with the order code Interface 9 assigned to the sense outputs.

# Rotary Measuring Technology

## Absolute Multiturn Encoder with optional incremental track



### Multiturn Type 5882 SSI or RS 485, programmable

#### Programmable function with optional Ezturn® software

Programmable features with optional programming tool Ezturn®:

- Type of code
- Resolutions per revolution
- Number of revolution
- Total resolution
- Direction of rotation
- Offset for mechanical zero point compensation etc....

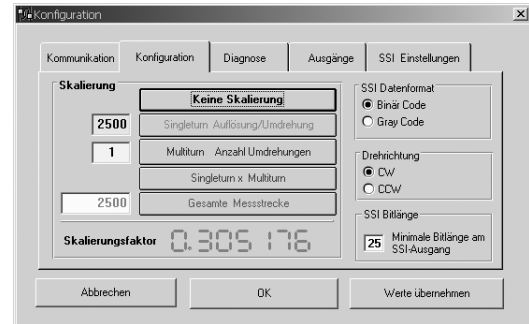

#### Terminal assignment SSI Synchronous Serial interface with 12pin plug

Signal:	0 V	+UB	+T	-T	+D	-D	ST	VR	A1	A2	A3	A4	⏏
Pin:	1	2	3	4	5	6	7	8	9	10	11	12	PH
Col.:	WH	BN	GN	YE	GY	PK	BU	RD	BK	VT	GY PK	RD BL	

T: Clock signal  
 D: Data signal  
 ST: SET input. The current position value is stored as new zero position (or the actual value is set to the preset

VR: value when using the programmable version).  
 Up/down input. As long as this input is active, decreasing code values are transmitted when shaft turning clockwise.

PH: Plug housing  
**Insulate unused outputs before initial start-up**  
 A1, A2, A3, A4: outputs, with Ezturn programmable

<sup>1)</sup>With the order code Interface 9 these outputs are assigned to the sense outputs. The sensor circuits are internally tied to the power supply. Special power supply units control the voltage drop in long cable runs via the voltage feedback. If the circuits are not being used, then they should be individually isolated and not connected.

#### Terminal assignment (RS485 interface 12 pin plug):

Signal :	0V	+UB	T/R-	T/R+	Term <sup>2)</sup>	Term <sup>2)</sup>		VR					⏏
Pin	1	2	3	4	5	6	7 <sup>1)</sup>	8	9	10	11	12	PH
Col.:	WH	BN	GN	YE				RD					

R = Receive-channel  
 T = Transmit-channel  
 VR: Up/down input. As long as this input (High-Level = +UB) is active, decreasing code values are transmitted when shaft turning clockwise.  
 PH = Plug housing

<sup>1)</sup> There is no SET input for the P3001 version but it can likewise be implemented using the command "<ESC>QP" (Write preset).

<sup>2)</sup>For the version with external termination: if the termination is desired (terminating resistor 120 Ohm), then both connections are to be tied together by means of a jumper (0 Ohm).

#### SSI interface with incremental track (A/B):

Signal :	0V	+UB	+T	-T	+D	-D	ST	VR	$\bar{B}$	B	$\bar{A}$	A	⏏
Pin	1	2	3	4	5	6	7*	8	9	10	11	12	PH

Encoder Type 5882 with stator coupling 2 wing



Encoder Typ 5882 with tether arm small



# Rotary Measuring Technology

## Absolute Multiturn Encoder with optional incremental track

Multiturn Type 5882 SSI or RS 485, programmable

Dimensions:

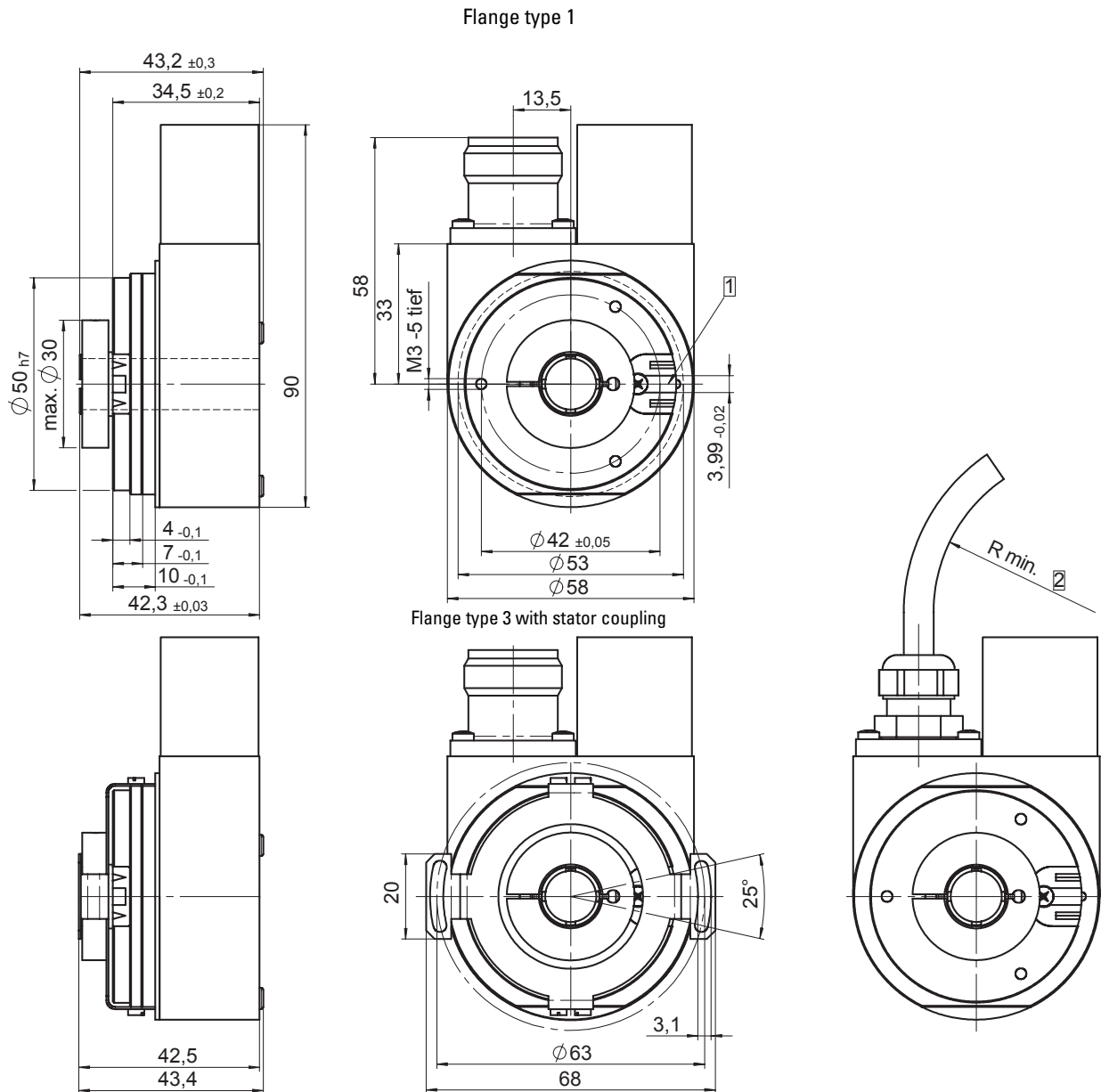

1 torque stop slot  
Recommendation: Cyl. pin. acc. to DIN 7-04

2 Cable,  
– securely installed: 55 mm  
– flexibly installed: 70 mm

Patented Intelligent-Sensing-Technology (IST)<sup>®</sup>

An innovative principle of operation based on a non-contact electronic multiturn stage overcomes system disadvantages previously associated with encoders that had mechanical gears or with traditional electronic gear technology.

### Advantages:

- High operational reliability
- Logic filter and innovative principle of operation compensate for high EMC interference
- Free from wear

# Rotary Measuring Technology

## Absolute Multiturn Encoder with optional incremental track



### Multiturn Type 5882 SSI or RS 485, programmable

Top view of mating side, male  
contact base:  
12 pin plug

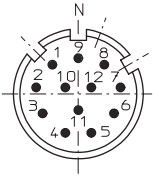

#### Order code:

**8.5882.XXXX.XXXX**

Range	
Flange	<p>1 = Flange type 1 with through shaft and torque support slot</p> <p><b>3 = Flange type 3 with through shaft and stator coupling*</b></p> <p>*Shaft clamping on other side on request</p>
Hollow shaft	<p>6 = Hollow shaft ø 10 mm</p> <p><b>8 = Hollow shaft ø 12 mm</b></p>
Interface	<p><b>2 = SSI 5 ... 30 V DC</b></p> <p>3 = RS 485, halfduplex 5 ... 30 V DC internal termination</p> <p>5 = SSI, 5 ... 30 V DC with incremental track 2048 ppr (A, B)</p> <p>7 = RS45, halfduplex 5 ... 30 V DC external termination</p> <p>9 = SSI 4.75 ... 30 V DC. with 2 status outputs and 2 sensor outputs for monitoring the supply voltage on the encoder.</p>
Type of connection	<p>1 = Radial cable (1 m PVC-cable)</p> <p><b>2 = 12 pin plug radial</b></p> <p>5 = Radial cable (5 m PVC-Cable)</p> <p>7 = Radial cable (10 m PVC-Cable)</p>

SSI-Interface *
2001 = 4096 x 4096 (24-Bit), Binary
2002 = 8192 x 4096 (25-Bit), Binary
2003 = 4096 x 4096 (24-Bit), Gray
<b>2004 = 8192 x 4096 (25-Bit), Gray</b>

RS 485-Interface halfduplex
3001 = ESC protocol, max. 38400 Baud

\*This factory set (default) resolution can be re-programmed by using the Ezturn® software.

#### Accessoires:

Corresponding mating connector to connection type 2  
Order code 8.0000.5012.0000

Programming kit Ezturn® includes

- Interface converter
- Connection cable with the interface converter encoder – PC
- 90-250 V AC power supply
- CD-ROM with Ezturn® software

Order code 8.0010.9000.0004



<b>Stock types</b>	8.5882.1622.2004
	8.5882.1822.2004

*Preferred types are  
fat marked*