

### High temperature Type 5823



- High temperature model up to 110 °C. Application at high temperatures, e.g. in drive technology
- Only 42 mm clearance needed
- Very easy mounting. The encoder is mounted directly on the drive shaft without couplings. This saves up to 30 % cost and 60 % clearance compared to shaft versions
- Many variations
- Temperature and ageing compensation
- Short-circuit proof outputs
- Reverse connection protection for voltage supply
- Resolution up to 5000 ppr
- IP 66
- available as explosion proof zone 2 and 22

#### Mechanical characteristics:

Speed without sealing:	max. 12000 min <sup>-1</sup>
Speed with sealing <sup>1)</sup> :	max. 6000 min <sup>-1</sup>
Rotor moment of inertia:	appr. 6 x 10 <sup>-6</sup> kgm <sup>2</sup>
Starting torque without sealing:	< 0,01 Nm
Starting torque with sealing:	< 0,05 Nm
Weight:	appr. 0,4 kg
Protection acc. to EN 60 529 without sealing:	IP 40
Protection acc. to EN 60 529 with sealing:	IP 66
Working temperature without sealing:	-20 °C ... +105 °C <sup>2)3)</sup>
Working temperature with sealing:	-20 °C ... +90 °C <sup>2)3)</sup>
Operating temperature without sealing:	-20 °C ... +110 °C <sup>2)3)</sup>
Operating temperature with sealing:	-20 °C ... +95 °C <sup>2)3)</sup>
Shaft:	stainless steel
Shock resistance acc. to DIN-IEC 68-2-27	2000 m/s <sup>2</sup> , 6 ms
Vibration resistance acc. to DIN-IEC 68-2-6:	100 m/s <sup>2</sup> , 10...2000Hz

<sup>1)</sup>for continuous operation max. 3000 min<sup>-1</sup> ventilated

<sup>2)</sup>non-condensing

<sup>3)</sup>depending on speed

#### Pulse rates available at short notice:

10, 20, 25, 30, 50, 60, 100, 120, 125, 127, 150, 180, 200, 216, 240, 250, 254, 256, 300, 314, 360, 375, 400, 500, 512, 600, 625, 720, 745, 750, 762, 800, 900, 927, 1000, 1024, 1250, 1270, 1400, 1500, 1800, 2000, 2048, 2250, 2400, 2500, 3000, 3600, 4000, 4096, 5000

Other pulse rates on request

#### Electrical characteristics:

Output circuit:	RS 422 (TTL-compatible)	Push-pull
Supply voltage:	5 V (±5 %) or 10 ... 30 V DC	10 ... 30 V DC
Power consumption (no load) without inverted signal:	–	typ. 55 mA / max. 125 mA
Power consumption (no load) with inverted signals:	typ. 70 mA / max. 100 mA	typ. 80 mA / max. 150 mA
Permissible load/channel:	max. ±20 mA	max. ±30 mA
Pulse frequency:	max. 300 kHz	max. 300 kHz
Signal level high:	min. 2,5 V	min. U <sub>B</sub> -2,5 V
Signal level low:	max. 0,5 V	max. 2,0V
Rise time t <sub>r</sub>	max. 200 ns	max. 1 μs
Fall time t <sub>f</sub>	max. 200 ns	max. 1 μs
Short circuit proof outputs: <sup>1)</sup>	yes <sup>2)</sup>	yes
Reverse connection protection at UB:	5 V: no; 10 ... 30 V: yes	yes
Conforms to CE requirements acc. to EN 61000-6-1, EN 61000-6-4 and EN 61000-6-3		

<sup>1)</sup>When supply voltage correctly applied

<sup>2)</sup>Only one channel at a time: (when U<sub>B</sub> = 5 V, short-circuit to channel, 0 V, or +U<sub>B</sub> is permitted.)  
(when U<sub>B</sub>=10 ... 30 V short-circuit to channel or 0 V is permitted.)

### High temperature Type 5823

#### Terminal assignment

Signal:	0 V	0 V	+U <sub>B</sub>	+U <sub>B</sub>	A	$\bar{A}$	B	$\bar{B}$	0	$\bar{0}$	Shield
		Sensor <sup>2)</sup>		Sensor <sup>2)</sup>							
12 pin plug; Pin:	10	11	12	2	5	6	8	1	3	4	PH <sup>1)</sup>
Cable colour:	WH	WH	BN	BN	GN	YE	GY	PK	BU	RD	
	0,5 mm <sup>2</sup>		0,5 mm <sup>2</sup>								

1) PH = Shield is attached to connector housing

2) The sensor cables are connected to the supply voltage internally and if long feeder cables are involved can be used for adjusting or controlling the voltage at the encoder

- If the sensor cables are not in use, they have to be insulated or 0 V<sub>Sensor</sub> has to be connected to 0 V and U<sub>B</sub><sub>Sensor</sub> has to be connected to U<sub>B</sub>

- Using RS 422 outputs and long cable distances, a wave impedance has to be applied at each cable end.

Insulate unused outputs before initial startup.

#### Dimensions

##### Flange Type 1

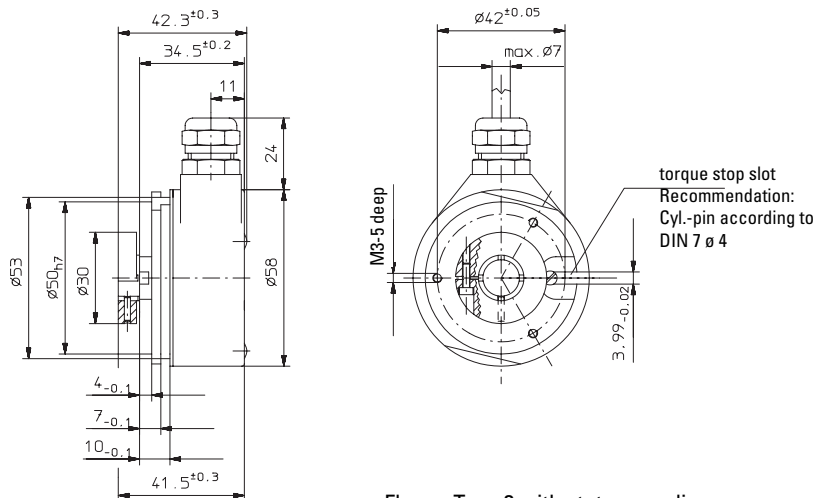

##### Flange Type 3 with stator coupling

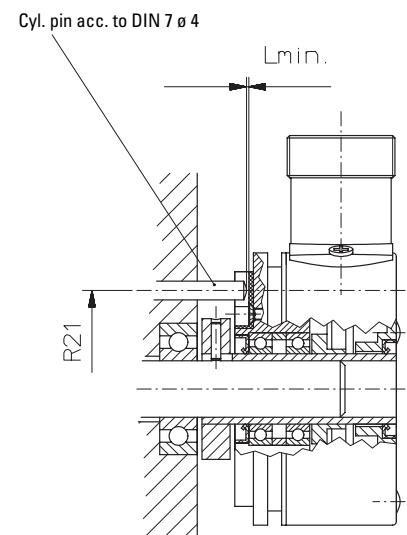
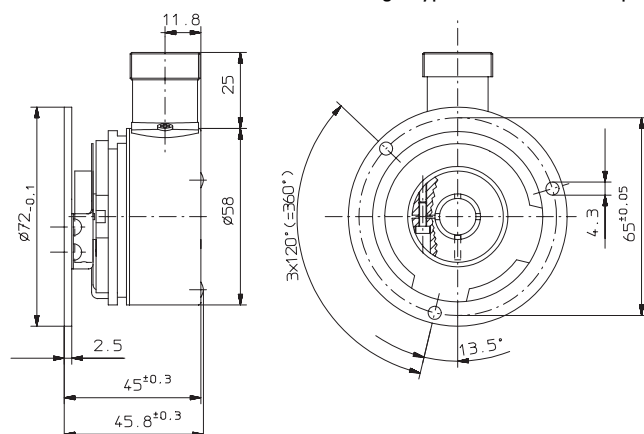

#### Mounting advice:

1) Do not connect encoder and drive rigidly to one another at shafts and flanges!

2) To mount a hollow shaft encoder, we recommend to use a torque stop pin that fits into the torque stop slot or a stator coupling.

3) When mounting the encoder ensure that Lmin. is larger than the axial play of the drive.

### High temperature Type 5823

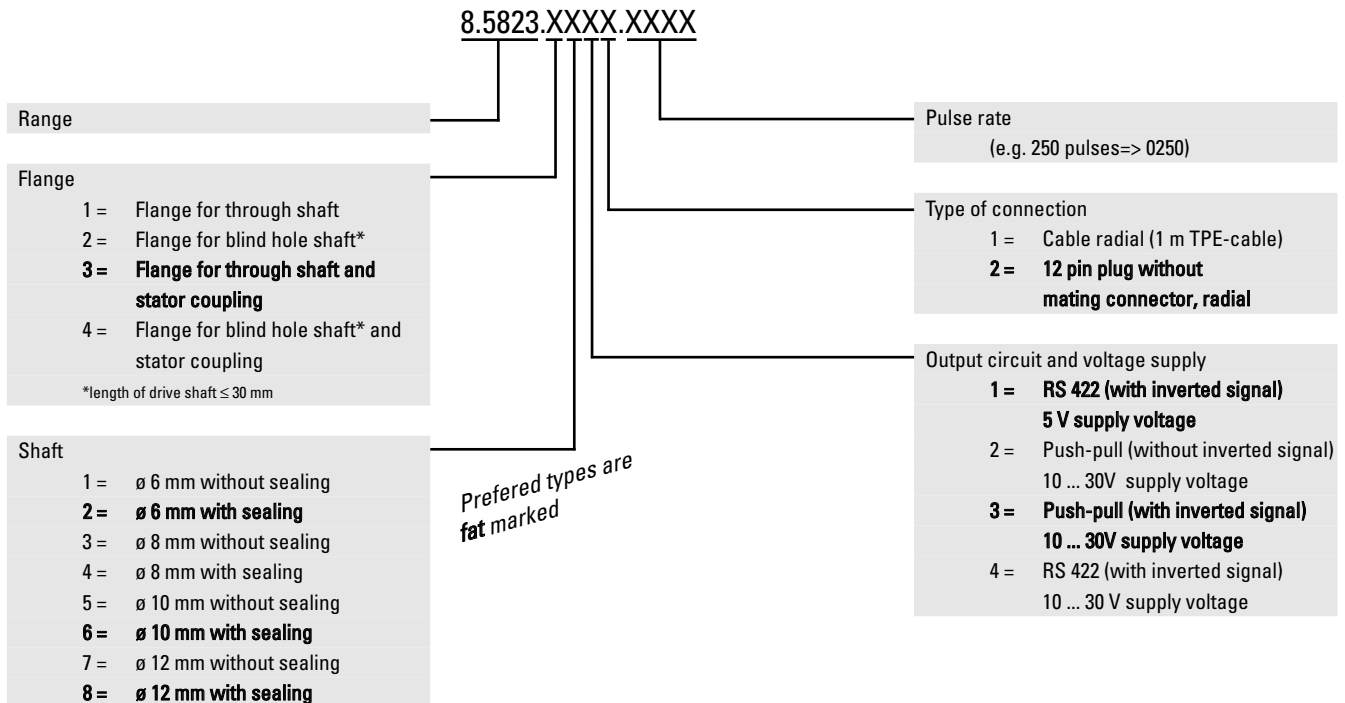

### Accessories

Corresponding mating connector to Type of connection 3 or 5, 12 pin: Art.-No. 8.0000.5012.0000 pin assignment ccw

Corresponding mating connector with cable pre-assembled: Art.- No. 8.0000.6101.XXXX (XXXX = length [m])

Set includes Connector typ 8.0000.5012.0000 and cable typ 8.0000.6100.XXXX (Cable PUR 10 x 0,14 mm<sup>2</sup> + 2 x 0,5 mm<sup>2</sup>)

#### PIN allocation:

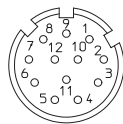

#### Dimensions:

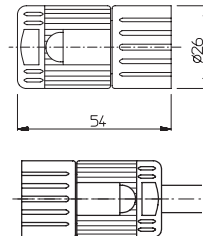

### Mounting kit for hollow shaft encoder ø 58 mm:

Various mounting variations can be supplied

Delivery includes:

- 1 x cylindric pin with thread  
Ord.-No. 8.0010.4700.0000
- 1 x mounting bracket  
Art.-no. T.035.009
- Screw M3x5  
Ord.-No. N.630.305
- 1 x long torque support slot  
Ord.-No. T.051.672

Complete set:  
Ord.-No. 8.0010.4600.0000

#### Stator coupling two wings

– for high dynamic application

Includes:

- 1x coupling two wings
- 2x 2 screws

#### Complete as set

Order-No.: 8.0010.4D00.0000  
(see page 235)

#### Tether arm short

Order-No.: 8.0010.4R00.0000  
(see page 238)