

Shaft version economy Type 3700



- Economical version
- Compact size only $\varnothing 37 \times 33$ mm
- Temperature- and ageing compensation
- Short circuit proof outputs
- Resolution up to 1024 ppr;
- Protection up to IP 67
- available as explosion proof zone 2 and 22

- Flange and cover made from a new High-Tech-Material (composite material)
- High component integration leads to low profile design, high performance and economical pricing
- "Tube Tech®" cable outlet guarantees 10x higher strain relief than traditional cabling methods
- Protection IP 67
- 1 1/2" (37 mm) diameter housing suitable for replacing resolvers.

Mechanical characteristics:

Speed:	max. 6000 min ⁻¹
Rotors moment of inertia:	appr. 0,4 x 10 ⁻⁶ kgm ²
Starting torque:	< 0,007 Nm
Radial load capacity of the shaft:	20 N
Axial load capacity of the shaft:	10 N
Weight:	appr. 0,1 kg
Protection acc. to EN 60 529:	bearing, shaft: IP 65 cable outlet: IP67
Working temperature:	-20° C up to +70 °C ¹⁾³⁾
Operating temperature:	-20° C up to +80 °C ²⁾³⁾
Materials:	shaft: stainless steel; housing, flange: composite PPA, 40% KF (carbon fiber) cable: PVC
Shock resistance acc. to DIN-IEC 68-2-27:	1000 m/s ² , 6 ms
Vibration resistance acc. to DIN-IEC 68-2-6:	100 m/s ² , 10 ... 2000 Hz

¹⁾ At push pull output and Supply voltage >15 V DC: max. 55 °C

²⁾ At push pull output and Supply voltage >15 V DC: max. 60 °C

³⁾ Higher temperatures up to 100 °C on request

Pulse rates available at short notice:

10, 50, 60, 100, 180, 200, 250, 300, 360, 400, 500, 512, 600, 1024

Other pulse rates available on request

Electrical characteristics:

Output circuit:	RS 422 (TTL-compatible)	Push-pull 7272
Supply voltage:	5 V (±5%)	5 ... 30 V DC
Power consumption (no load) with inverted signal:	typ. 40 mA / max. 90 mA	typ. 50 mA/ max. 100 mA
Permissible load/channel:	max. ±20 mA	max. ±20 mA
Pulse frequency:	max. 250 kHz	max. 250 kHz
Signal level high:	min. 2,5 V	min. U _B -2,0 V
Signal level low:	max. 0,5 V	max. 0,5 V
Rise time t _r	max. 200 ns	max. 1 µs
Fall time t _f	max. 200 ns	max. 1 µs
Short circuit proof outputs ¹⁾ :	yes ²⁾	yes
Reverse connection protection at U _B :	no	no
Conforms to CE requirements acc. to EN 61000-6-1, EN 61000-6-4 and EN 61000-6-3		

¹⁾ When supply voltage correctly applied

²⁾ Only one channel at a time:
(at U_B = 5 V short circuit to channel, 0 V, or +U_B is permitted).

Applications:

- Substitute for resolvers
- Packaging machines
- Electrical machines
- Vehicles
- Conveyers, elevators
- Semiconductor machines
e.g pick & place, cutting ...
- Material handling
- Special machines.

Rotary Measuring Technology

Incremental shaft encoder



Shaft version economy Typ 3700

Signal:	0 V	+U _B	A	\bar{A}	B	\bar{B}	0	$\bar{0}$	Shield
Colour:	WH	BN	GN	YE	GY	PK	BU	RD	

Using RS 422 outputs and long cable distances, a wave impedance has to be applied at each cable end.

Insulate unused outputs before initial startup.

Dimensions:

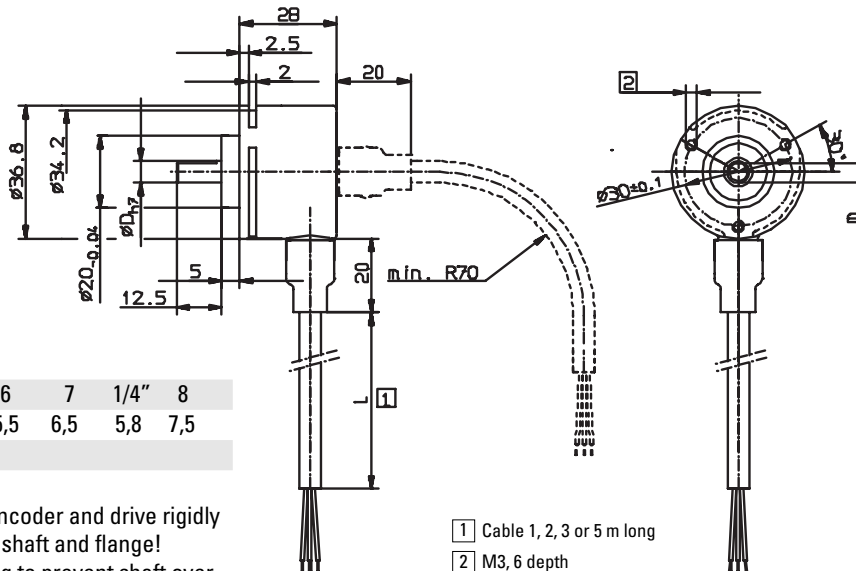

D	4	5	6	7	1/4"	8
m	3,7	4,6	5,5	6,5	5,8	7,5

Mounting advice:

Do not connect the encoder and drive rigidly to one another at the shaft and flange!
Always use a coupling to prevent shaft overload (see chapter accessories).

- 1 Cable 1, 2, 3 or 5 m long
- 2 M3, 6 depth

Order code:

8.3700.XXXX.XXXX

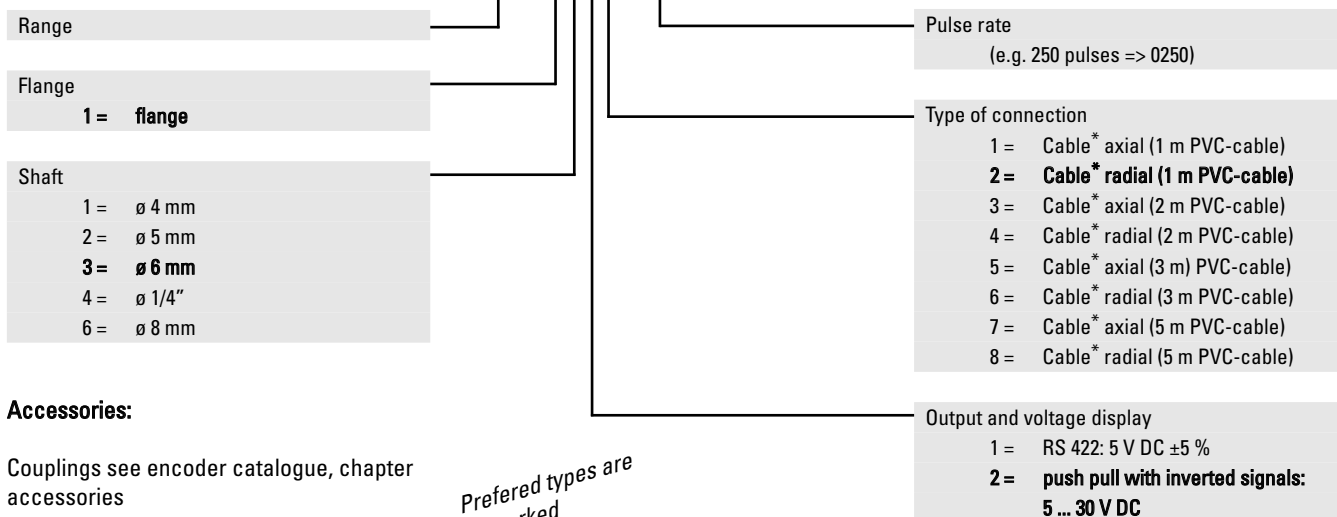

Preferred types are fat marked

Accessories:

Couplings see encoder catalogue, chapter accessories

Stock types
8.3700.1322.0050
8.3700.1322.0360
8.3700.1322.0500
8.3700.1322.1000
8.3700.1322.1024

* "Tube Tech®" cable outlet guarantees 10x higher strain relief than traditional cabling methods plus higher IP-Protection.

Other cable lengths on request.