

Rotary Measuring Technology

Absolute multiturn encoder shaft version

Multiturn Type 5862S SSI standard line



Your benefit:

- High operational reliability and best suited for dynamic applications through to its contactless multiturn stage with the proven Intelligent-Sensing-Technologie (I-S-T)
- Very compact configuration by construction with Integrative Technology
- High service lifespan in rough application conditions due to its high shock and vibration resistance

Applications:

Positioning, distance measurements, lengths and angles in machines and systems, logistics and handling, drive and propulsion technology, vehicle technology, medicine technology, elevator technology,

Mechanical characteristics:

Speed:	max. 6 000 min ⁻¹
Rotor moment of inertia:	appr. 1,8 x 10 ⁻⁶ kgm ²
Starting torque shaft version:	< 0,01 Nm
Radial load capacity of shaft: ²⁾	80 N
Axial load capacity of shaft: ²⁾	40 N
Weight:	appr. 0,4 kg
Protection acc. to EN 60 529:	IP 65
Working temperature:	-20° C ... +70 °C
Operating temperature:	-20° C ... +80 °C
Shaft:	stainless steel
Shock resistance acc. to DIN-IEC 68-2-27	2500 m/s ² , 6 ms
Vibration resistance acc. to DIN-IEC 68-2-6:	100 m/s ² , 10 ... 2000 Hz

²⁾ for shaft version only (at shaft end)

Electrical characteristics:

Interface type:	Synchronous-Serial (SSI)
General information	
Supply voltage (U _B):	5,0 ... 30 V DC ³⁾
Current consumption type (no load):	89 mA
max (no load):	138 mA
Short circuit proof outputs: ¹⁾	yes ²⁾
Reverse connection protection at U _B :	yes
SSI-Interface:	
Output driver:	RS 485
Permissible load/channel:	max. +/-20 mA
Update rate for position data:	approx. 1600/s
SSI pulse rate min./max./pulse frequency:	100 kHz/500 kHz
Signal level high:	typ. 3,8 V
Signal level low (I _{Last} = 20 mA):	typ. 1,3 V
Rise time t _r (without cable):	max. 100 ns
Fall time t _f (without cable):	max. 100 ns
Control inputs:	
Voltage:	5 ... 30 V DC = U _B
response time:	10 ms
Signal level: low	max. 25% U _B
high	min. 60% U _B , max. U _B
Max. current input	≤0,5 mA

Status output:

Output driver:	Push-Pull
Battery monitoring	max. permissible load: ±9,0 mA
	Signal level high: min. U _B - 3,0 V
	low: max. 1,5 V
	Rise time: max. 240 μs
	Fall time: max. 300 μs

Conforms to CE requirements acc. to EN 61000-6-1, EN 61000-6-4 and EN 61000-6-3 Performance against magnetic influence acc. to EN61000-4, 5

- ¹⁾ when U_B supply voltage correctly applied U_B
²⁾ Only one channel at a time:
 When U_B = 5 V DC, short-circuit to output, 0 V and + U_B is permitted.
 When U_B < 5 V DC short-circuit to output and 0 V is permitted.
³⁾ The supply voltage at the encoder input must not be less than 4.75 V (5 V - 5%)

Multiturn Type 5862S SSI standard line

Control inputs:

F/R input for change of direction:

The encoder can output increasing code values when the shaft is rotated either clockwise or counter-clockwise (when looking from the shaft side). This option must be selected before the operating voltage is supplied.

Hardware configuration of the F/R input	Function: increasing code value when the shaft is in the following direction:
"low" (0V) on the F/R input (=cw) (advantage position setting through internal pull-down resistor)	cw
"high" (+UB) on the F/R input (= ccw)	ccw

Notes:

– If the direction of rotation is changed due to the F/R configuration, without activating the SET function again, and if the encoder is also then powered up again, a new position value may be outputted, even if the physical shaft position of the encoder has not moved! This is due to internal conversion processes.

The start-up procedure for the encoder should therefore follow this sequence:

1. Determine the count direction of the encoder either via the F/R input
 2. Apply power to the encoder
 3. Activate the SET function, if desired (see SET input below)
- If using a cable wire to configure the F/R input, then for EMC reasons the wire should not remain open but should be tied either to 0V or UB!

SET input:

This input is used for a alignment (zeroing) of the encoder. A high control pulse (+UB) applied to this input will reset the current encoder position to zero.

Notes:

- The SET function should only be implemented when the encoder shaft is at rest.
- For the duration of the SET pulse the SSI interface does not function and therefore does not output any valid position values! In order to avoid malfunctions, no SSI clock pulse should occur during the SET pulse.

- If a cable wire is used to configure the SET input, then for EMC reasons the wire should not remain open but should if at all possible be tied to 0 V, provided no SET pulse is triggered!

Terminal assignment:

Signal :	0V	+UB	+T	-T	+D	-D	ST	VR	A1	⏏
Pin	1	2	3	4	5	6	7	8	9	PH
Col.:	WH	BN	GN	YE	GY	PK	BU	RD	BK	

T: Clock signal
D: Data signal
ST: SET input. The current position value is stored as new zero position

VR: Up/down input. As long as this input (High-Level = + UB) is active, decreasing code values are transmitted when shaft turning clockwise.
PH = Plug housing
Insulate unused outputs before initial start-up

Top view of mating side::

12 pin plug

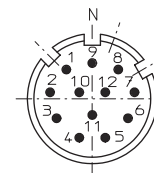

Patented Intelligent-Sensing-Technology (IST)[®]

An innovative principle of operation based on a non-contact electronic multiturn stage overcomes system disadvantages previously associated with encoders that had mechanical gears or with traditional electronic gear technology.

Advantages:

- High operational reliability
- Logic filter and innovative principle of operation compensate for high EMC interference
- Free from wear

Multiturn Type 5862S SSI standard line

Dimensions:

Clamping flange

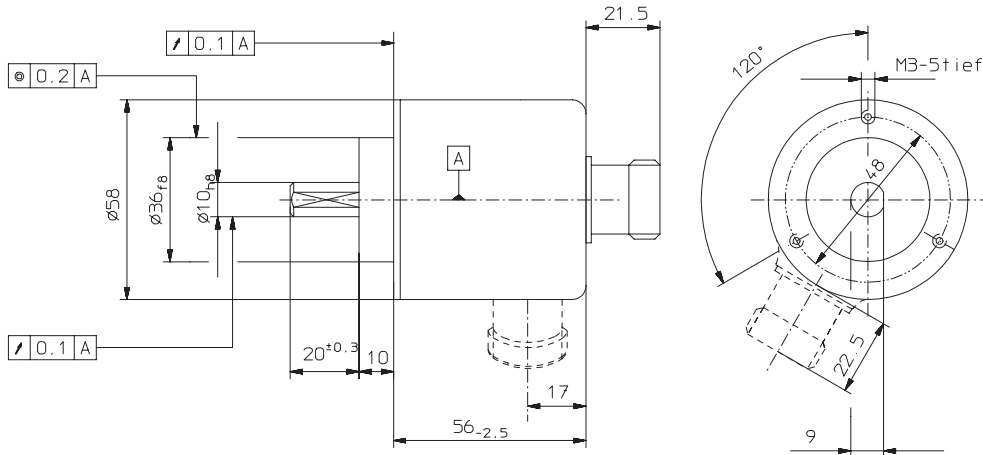

Synchronous flange

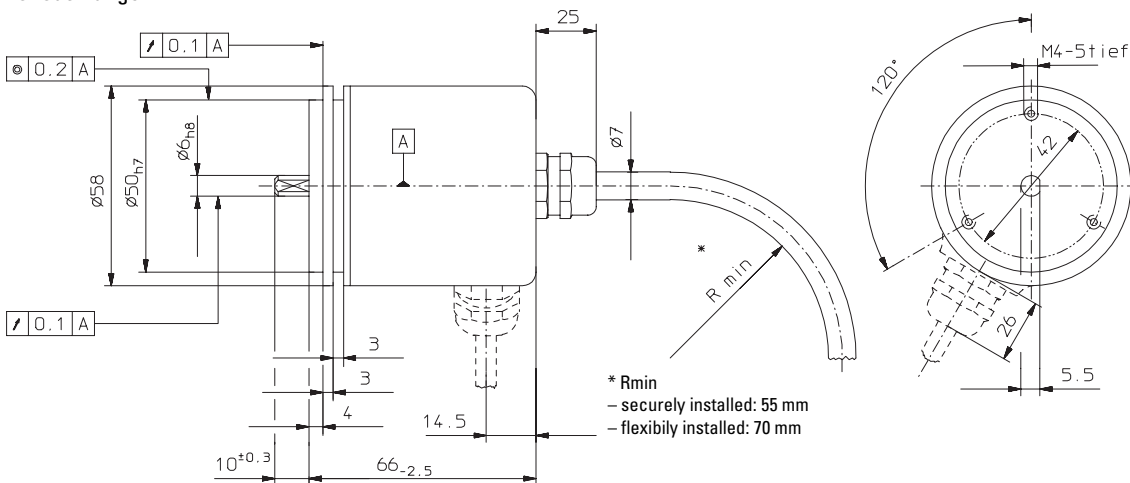

Order code:

8.5862S.XXXX.XXXX

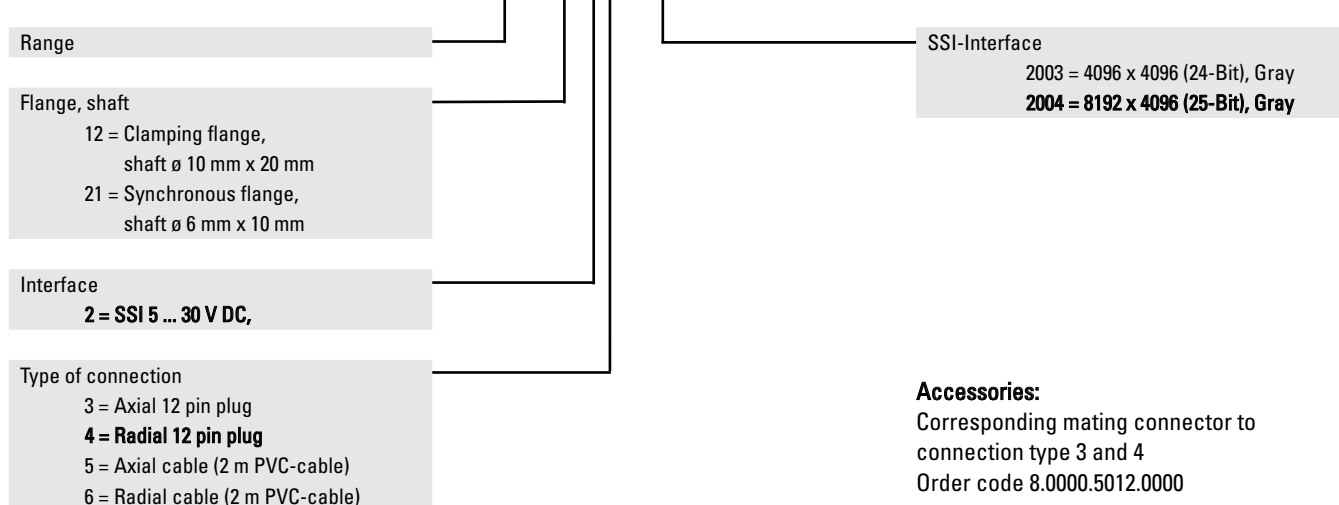

Accessories:
Corresponding mating connector to connection type 3 and 4
Order code 8.0000.5012.0000