

BOSTER

STAND-ALONE without safety module

CODED SWITCH WITH MAGNETIC LATCH FOR THE MOVING PROTECTORS OF DANGEROUS MACHINES

- ➔ Magnetic latch 4 Kg
- ➔ Decoding by Acotom®3 process
- ➔ Mechanical contacts 2A/48V
- ➔ Auxiliary output for automation control or lights
- ➔ Stainless steel 316L housing
- ➔ Laser marking
- ➔ Protection class IP67
- ➔ Temperature -20°C to +60°C

CATEGORY 3

ACOTOM®3

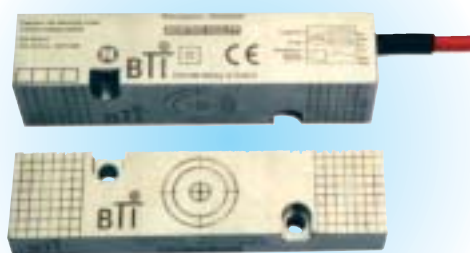

WITH MAGNETIC LATCH

EN954-1

STAINLESS STEEL 316L LASER MARKING

SAFETY CATEGORY

- BOSTER : category 3***
- BOSTER in series + safety module : category 4***
- *whatever the number of switches in series**

ELECTRICAL DIAGRAM

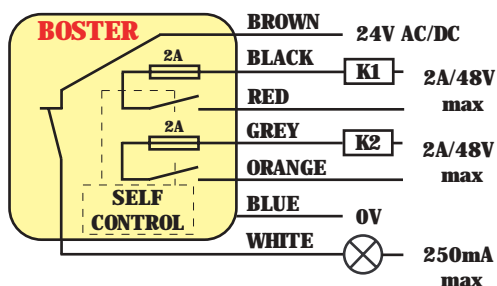

cat.3

DIMENSIONS

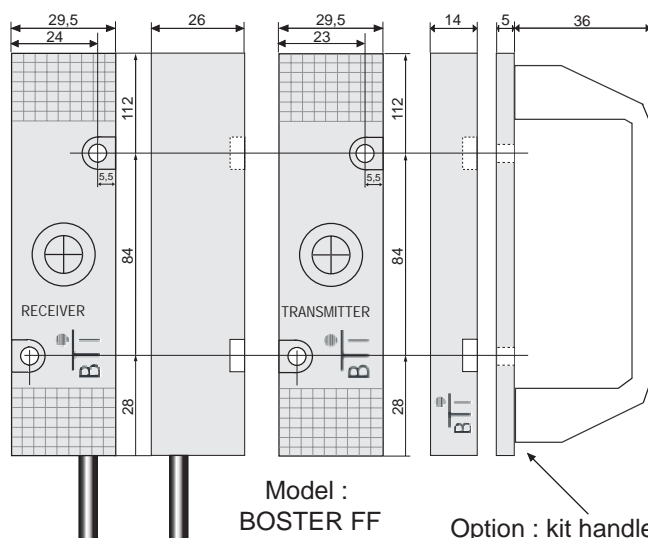

Standard cable 3/6/12m Diam. 5

Option : kit handle and stainless steel plate

Other fixing mode, please consult us.

BOSTER in case of failure



Our switches are equipped with a 2A fuse to guarantee the electrical protection.

ADVICE

Thanks to the stainless steel 316L and laser marking, this product can be used in the dairy industry. Door latches up to 5m². The marking is still readable after cleaning.